



Thank you for purchasing our stainless steel tank we appreciate your business

Installation Instructions for Bolt In Kit PN 27000

Parts Included:

- 7 - 1/4-20 Nylon nuts
- 7 - 1/4-20 x 1.5" Countersunk bolts
- 1 - Lock Ring
- 1 - Bolt Ring
- 1 - Lock Ring
- 1 - Foam Ring
- 1 - C - Ring
- 1 - Hole Saw

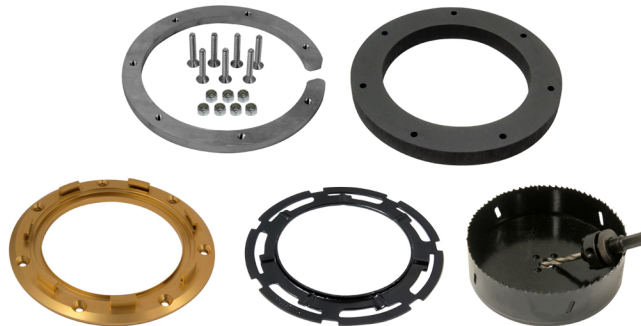

Tools Required:

- Power Drill
- 5/32 Allen Wrench
- 7/16 Wrench

Step 1

Find the deepest part of the fuel tank. Measure the center of the tank.

Step 2

Cut the hole in the tank using the provided hole saw.

Step 3

Clean all debri and clean off sharp edges with a file.

Step 4

Install Kit

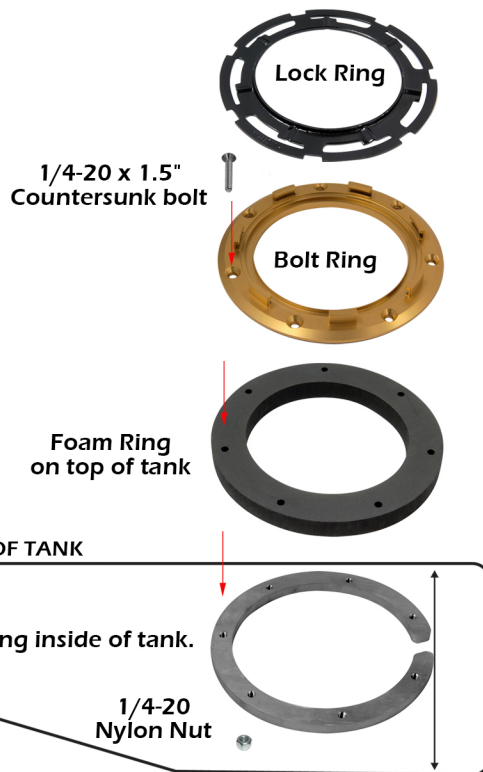
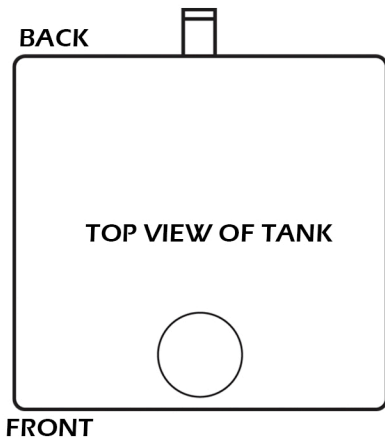

Bolt in Kit Installed



WARNING:

This product may expose you to chemicals which are known to the state of California to cause cancer. For more information, go to www.P65Warnings.ca.gov.